

# The 360 Series Label Applicator

**CTM** **INTEGRATION INC.**  
*Labeling Systems Built to Last*

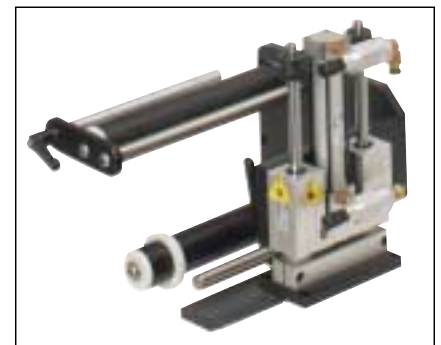

*Tamp Blow Module*



*Air Blow Module*

*Innovations in Labeling*  
[www.ctmint.com](http://www.ctmint.com)

# The 360 Series Label Applicator

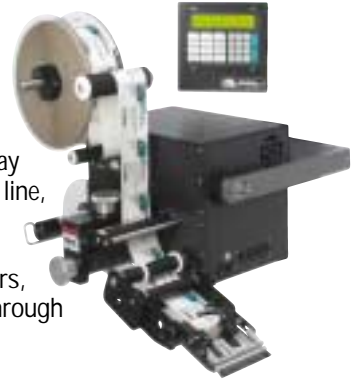

## Features:

The 360 Series Label Applicator is a rugged, versatile labeler loaded with standard features not found on most other applicators. The 360 can be configured as a merge, blow-on or tamp-blow applicator and each module can also be easily switched to an opposite hand with no change parts in a minimum of time. The 360 is available in 5", 7-1/2" and 10" widths and all units are stepper motor driven and include Dual Microprocessors, State-of-the-art electronics, intelligent control equipped with onboard I/O, and a "Self-teaching" label sensor.

## Stepper Motor

The 360 stepper drive uses a micro pulse driver for increased accuracy and performance, and is programmable to dispense labels at up to 2100 inches per minute.

## Control

The 360 is equipped with state-of-the-art electronics featuring a Dual Microprocessor control - One 32-bit processor supervises the application program while a digital signal processor (DSP) supervises the motion loop resulting in faster response times and improved application accuracy. The 360 controller is also equipped with onboard I/O pre-wired to external connectors to accommodate the following:

<i>low label</i>	<i>tamp home and extend switching</i>
<i>web break</i>	<i>encoder velocity compensation</i>
<i>loose loop control</i>	<i>product shape profiling</i>
<i>imprinting</i>	<i>zero downtime configuration</i>

Each machine is shipped preprogrammed and can have the additional hardware installed at a later date for simple "plug n play" operations. The electronic control assembly is packaged as a module and can be easily removed for repair or replacement, eliminating costly downtime and servicing.

## Operator Interface

The self-prompting user-friendly display control comes with an easy to read, 4 line, 40 character LCD display. Dedicated soft keys allow quick access to the most frequently used set up parameters, thus eliminating lost time searching through complicated menus.

## Electrical:

108-132 VAC, 50/60 Hertz, Single Phase, 10 amps.

## Air Consumption:

Up to 4 CFM at 60-90 psi.

## Labeling Speeds:

Programmable to 1500 inches per minute, to 2100 IPM with over-size unwind and rewind. Programmed with speed profiling ability.

## Product Sensing:

Retroreflective scanner provided as standard, other types available

## Label Sizes:

	<i>Minimum</i>	<i>Maximum</i>
<i>Air Blow</i>	<i>3/4" wide x 3/4" L</i>	<i>5" wide x 5-1/2" L</i>
<i>Merge</i>	<i>3/4" wide x 3/4" L</i>	<i>5" wide x 20" L</i>
<i>Tamp</i>	<i>3/4" wide x 3/4" L</i>	<i>5" wide x 10" L</i>

## Label Roll Size:

<i>Maximum</i>	<i>12" OD x 3" ID core</i>
<i>Optional</i>	<i>16" OD or 20" OD x 3" or 6" ID cores</i>

## Label Placement:

*+/- 1/32"*

## Dimensions:

<i>Air Blow</i>	<i>28" wide x 24" Tall x 27-1/2" Deep</i>
<i>Merge</i>	<i>29" wide x 25" Tall x 27-1/2" Deep</i>
<i>Tamp</i>	<i>28" wide x 22-1/2" Tall x 27-1/2" Deep</i>

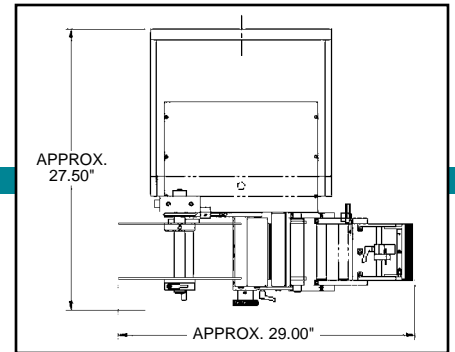
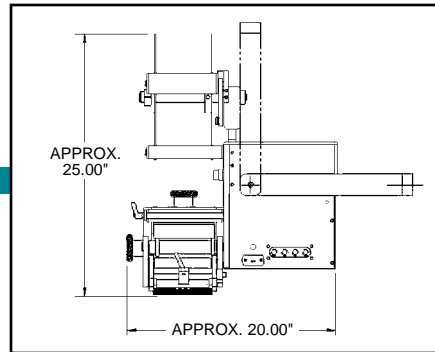
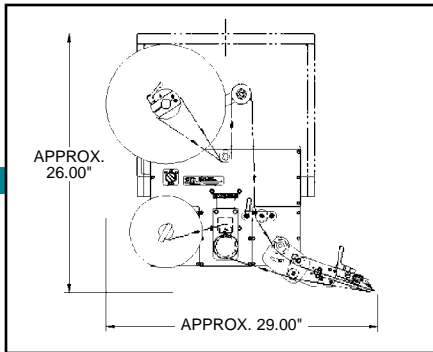

Distributed By:

**CTM** **INTEGRATION INC.**  
Labeling Systems Built to Last

1318 Quaker Circle  
P.O. Box 589  
Salem, Ohio 44460  
(330) 332-1800

[www.ctmint.com](http://www.ctmint.com)