



NORTHFIELD CORPORATION

O.E.M. OF NORTHFIELD ELASTITAG® APPLICATORS

ElastiTag® Applicator



Featuring:

- Complete parts inventory on all equipment
- Service technicians available 24 hours a day, 7 days a week.
- Over 25 years experience worldwide with numerous companies, both large and small
- In-field consultation

Dedicated to efficient installation, service, and sales of pressure sensitive labelers, coupon inserting equipment, and neck hanger/ElastiTAg® applicators which ensures that the correct equipment is used for every job, every time.

NORTHFIELD ELASTITAG® APPLICATOR

ElastiTag® Applicator Specifications:

Power Requirements: 115/230 VAC filtered, 50-60 cycles,
8 amps.

Max Speed: Up to 180 tags per minute
*Dependent on tag size and product

Product Cap/Neck sizes: 1/2" to 4" width, custom sizes available

Controls: Applied Motion Products, Maple Systems
Controller Dimension: 16" High, 14" Wide, 10" Deep

Head Weight: 30 lbs.
Controller Weight: 40 lbs.
Lubrication Needs: None
Change Parts: None
Air Requirements: None

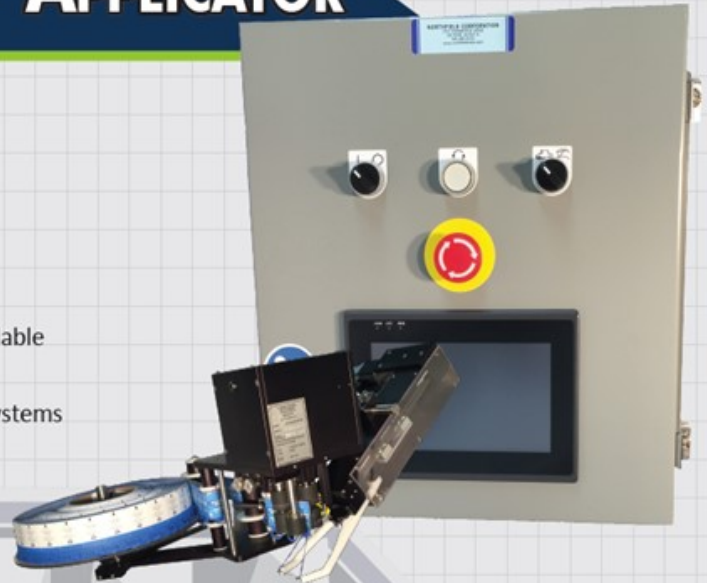

ElastiTag® Requirements:

Minimum Tag Length in Feed Direction: 1"
Maximum Tag Size: TBD
Maximum Tag Thickness: 1/16"
Tag Supply: Max 16" OD Rolls,
6" ID Core

The Northfield ElastiTag® Applicator is capable of accurately applying ElastiTags® to bottle necks of all shapes and sizes. The ElastiTag® Applicator can be provided for semi-automatic operation or in line with a hugger belt system or timing screws in order to hold the correct spacing. Custom options available also.

Application examples: liquor bottles, milk bottles, juice bottles, soda bottles, water bottles, spray bottles, etc.

Dimensions, Head

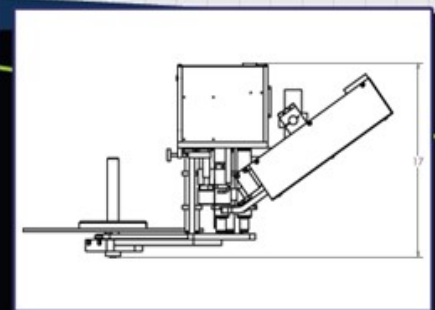
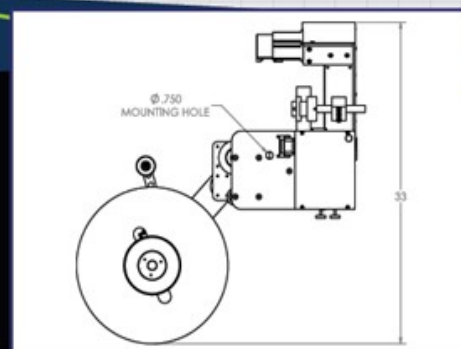
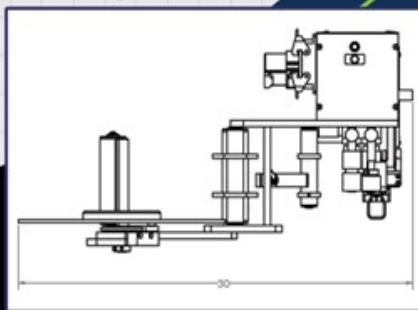

Distributed by:

NORTHFIELD CORPORATION

1870 Commerce Drive • De Pere, WI 54115
920-983-8122 • Fax 920-983-8124

www.northfieldcorp.com