



# NORTHFIELD CORPORATION

O.E.M. OF NORTHFIELD CONTINUOUS FEED COUPON INSERTERS

## 1600SRV 2D Coupon Inserter



### Featuring:

- Complete parts inventory on all equipment
- Service technicians available 24 hours a day, 7 days a week.
- Over 25 years experience worldwide with numerous companies, both large and small
- In-field consultation

Dedicated to efficient installation, service, and sales of pressure sensitive labelers, coupon inserting equipment, and neck hanger/ElastiTag® applicators which ensures that the correct equipment is used for every job, every time.

# NORTHFIELD 1600SRV INSERTER

## Continuous Feed Inserter Specifications:

Power Requirements:	115/230 VAC filtered, 50-60 cycles, 5 amps.
Max Speed:	Up to 400+ pieces per minute *Dependent on insert size and product
Linear Speed, In-Feed:	Up to 6,000 I.P.M.
Linear Speed, Out-Feed:	Up to 6,000 I.P.M.
Controls:	Applied Motion Products, Maple Systems
Controller Dimension:	16" High, 14" Wide, 6" Deep



Head Weight:	25 lbs.
Controller Weight:	34 lbs.
Lubrication Needs:	None
Change Parts:	None
Air Requirements:	None

## Standard 2-D Insert Size and Specifications:

Minimum Insert Size:	1" Wide x 1" Long
Maximum Insert Size:	6" Wide x 7" Long
Insert Thickness:	Up to 1/16"
Splices:	Heat Seal Factory Splices Only
Burst Tensile Strength:	8-12 lbs. Recommended not to exceed 17 lbs.

The Northfield Model 1600SRV 2D inserter is capable of accurately inserting 2D overwrapped, NX2Food, and perforated paper inserts; either in roll or bandoiler form. Some of the application examples are: horizontal/vertical fillers, carton lines, open container lines, and hot melt on/in pack applications.

Insert examples: game pieces, sweepstakes, coupons, instructions, rebates, etc.

Dimensions, Head

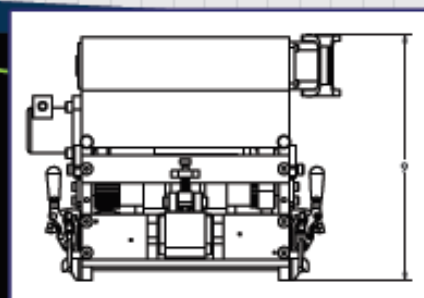
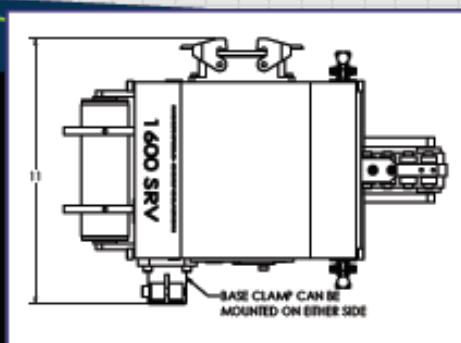
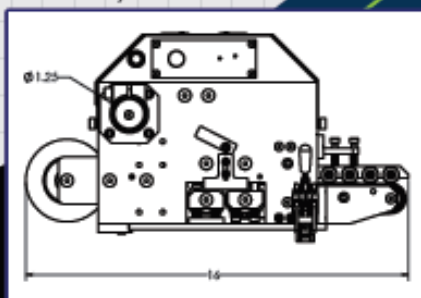

Distributed by:

## NORTHFIELD CORPORATION

1870 Commerce Drive • De Pere, WI 54115  
920-983-8122 • Fax 920-983-8124

[www.northfieldcorp.com](http://www.northfieldcorp.com)