

# NORTHFIELD CORPORATION

O.E.M. OF NORTHFIELD CONTINUOUS FEED COUPON INSERTERS

Service • Installation • Labelers • Inserters

## Model CLS

## Compact Labeling System



optional merge module



### Featuring:

- Complete parts inventory on all equipment
- 9 service technicians available 24 hours a day, 7 days a week.
- 80 + years combined experience nationwide with numerous companies, both large and small
- In-field consultation

*Dedicated to efficient installation, training, service and sales of coupon inserting equipment and pressure sensitive label applicators.*

# MODEL CLS



## Compact labeling system specifications:

Power requirements: 120 VAC 50/60 HZ, single phase, 10 amps.  
Max speed: Up to 900+ pieces per minute (1.5" insert length)  
Controls: Applied Motion; DC Servo Drives  
Dimensions, Controller: 14" high, 12" wide, 7" deep  
Weight, Head: 40 lbs.  
Weight, Controller: 27 lbs.  
Lubrication needs: None  
Air requirements: Up to 4 CFM @ 60 – 90 PSI

## Optional:

Extended snorkel available for vertical form fill and seal machines

## Standard label sizes and specifications:

Minimum label size: .75" wide x .75" long  
Maximum label size: 4" wide x 8" long (MERGE)  
3" wide x 4" long (RVB)  
Rolls up to 16" diameter

Label Placement: +/- 1/32"

*Note: Performance rates based on compliance with label specifications as described above as well as all machine performance safe guards in place. Operators must be fully trained and take complete ownership of equipment.*

## In Shop Warranty:

The Model CLS has a 12-month warranty on non-wear parts, a six month warranty on wear parts and a 90 day warranty on in-feed/nip rollers.

## Dimensions, Head:

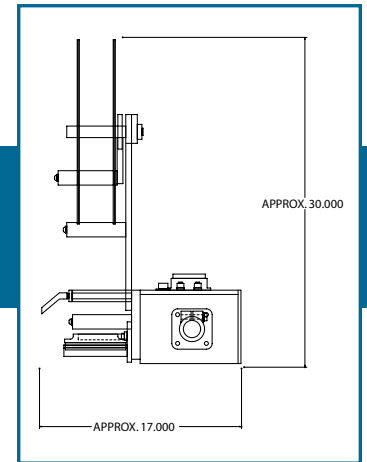
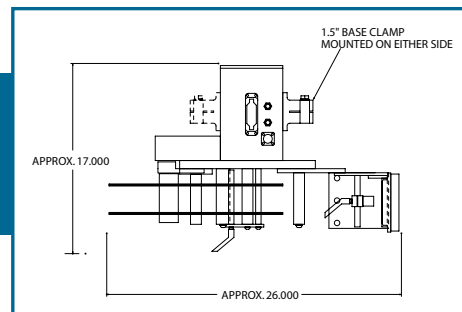
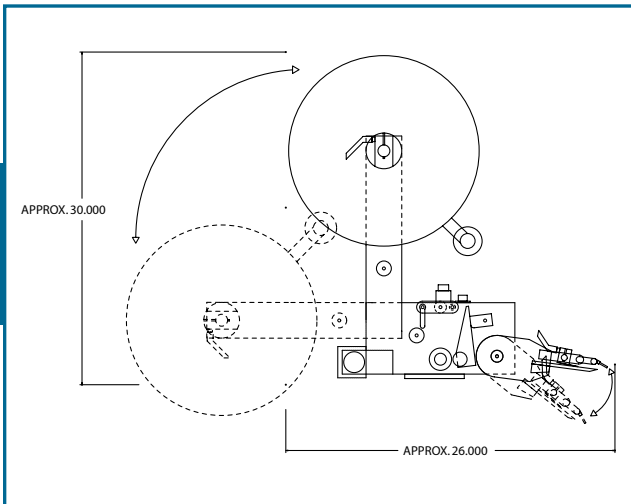

*Distributed by:*

## **NORTHFIELD CORPORATION**

1870 Commerce Drive • De Pere, WI 54115

920-983-8122 • Fax 920-983-8124

[www.northfieldcorp.com](http://www.northfieldcorp.com)